

manatee[™]

English manual

GB CONTENTS

Safety	4
Guarantee.....	4
Maintenance	4
Preparing for use	5
Back angling	6
Leg support angling	6
Seat depth	7
Seat height	7
Seat angling.....	8
Head / sidesupport	8
Hip support	9
Body support	9
Pommel with strap	10
Straps for leg control	10
Dismounting and mounting the cover	11
Folding the chair	12
Frame	13
Wall fittings for frame	14
Product identification	15
Measurements.....	16
Technical data.....	17
Producer	17
Distributor	17
Care and maintenance	18
Troubleshooting	18

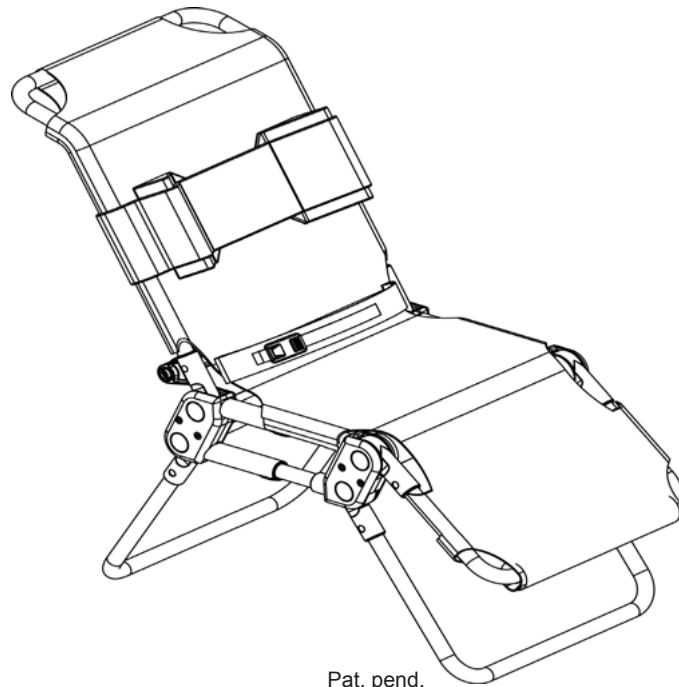

GB MANATEE

Congratulations on your new Manatee bathing chair. In choosing the Manatee, we are sure that you have got a bathing chair, which will live up to any expectations one can have for a modern aid for children. The Manatee is designed to be used in bathrooms, in which the child can not ever be left alone.

The Manatee is a bathing chair for children between 2 and 11 years with a lesser handicap. The Manatee is constructed to provide both caregivers and users a wonderful bathing experience. The bathing chair is designed to place the user in exactly the right sitting position. The depth of the seat can be adjusted, allowing the bathing chair to "grow" with the child and provide many years of use. The adjustments and accessories are logically positioned, affording the caregiver proper working conditions.

This user manual is meant as a guide to assist the user in gaining the full benefit of the many options offered by the Manatee. Therefore we recommend you to go through this manual before the Manatee is put into use.





GB SAFETY

The Manatee has earned the CE-mark. This certifies that it meets all relevant European safety requirements. The durability of this product is 5 years when it is used on a daily basis. Hereafter we recommend that the product should be renovated (by R82 personnel) to extend the lifetime.

 Remove the CE-mark, when rebuilding the product or when using other than original R82 spare parts.

 Never leave your child unattended in this product. Ensure permanent supervision by an adult. Incorrect use of the Manatee, may cause serious injury to the user. Take care that all the accessories and adjustments are placed and fitted correctly and check it on a regular basis.

 The user must be removed from the product, before angling the chair legs. We recommend to remove the pressure load from the users body and legs, before angling the back and leg support. Put a gentle back pressure on the back and leg support to remove the pressure load.

 Check the temperature of the water before the Manatee and the child is placed in the bath.

 The enclosed belts and accessories can not be used as long-term supports but may only be used as an extra help when positioning the user.

 Secure the chair when any adjustments have been made. Then place the user on to the Manatee.

 Check on the cover, belts and accessories and make sure that the velcro fastens securely.

GB GUARANTEE

Notification of defects will be received at R82 A/S within two years.

The Manatee is guaranteed for 12 months. The guarantee is only valid when using original R82 spare parts and fittings. All special adjustments must be made by R82. R82 will not be held responsible for damage or injury caused by use of non-original parts or repairs made by a non-authorized R82 person.

GB MAINTENANCE

 When the chair has been used in water containing chlorine it has to be washed out with clean water and dried with a cloth. Make sure that all water is out of the frame.

 Do not use any cleaning materials containing chlorine or methylated spirit.

 All screws on the chair have to be checked regularly to avoid unintended failures.

 Adjustments which are not described in this manual, must only be made by authorized R82 personnel.

GB PREPARING FOR USE

We deliver the Manatee folded which means it takes up as little space as possible during transport. Follow the instructions below to prepare your bathing chair for use:

- 1) Press the release buttons (A) on both sides and fold down the chair legs.
- 2) Press the release buttons (B) on both sides and fold down the leg support.
- 3) Press the release buttons (C) on both sides and pull up the back.

The Manatee is ready for use.

 Please check that all release buttons mesh into place after adjustment.

 Never leave the user unattended in the Manatee.

 The user must be removed from the product, before angling the chair legs. We recommend to remove the pressure load from the users body and legs, before angling the back and leg support. Put a gentle back pressure on the back and leg support to remove the pressure load.

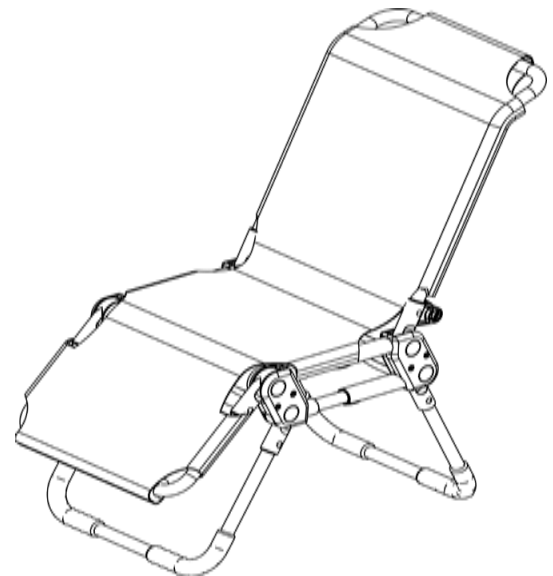
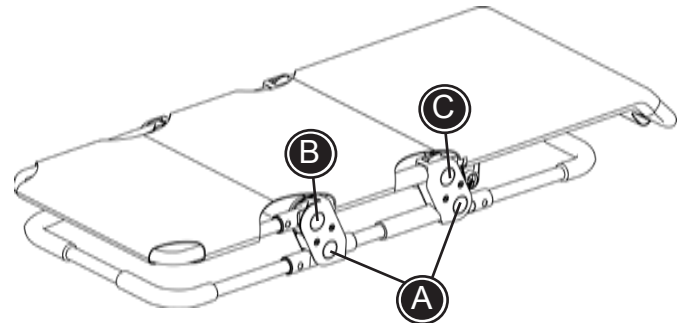

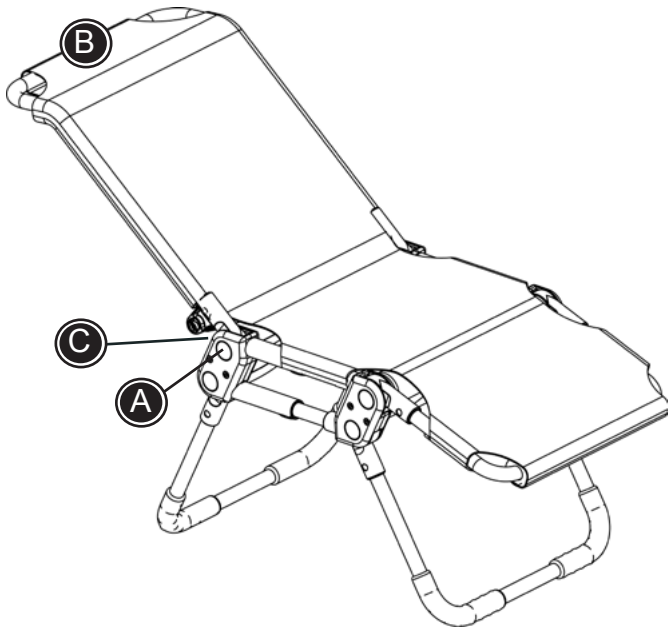

GB BACK ANGLING

The back on the Manatee angles individually. Please follow the description below when angling the back:

- 1) Press the release buttons (A) in both sides.
- 2) Angle the back (B) into the required position.
- 3) Please check that both release buttons (A) mesh into place after adjustment.

Further, the back also angles by pulling the strap on the back of the chair.

! Please take care not to get your fingers caught between the rotary joint and the back (C).

! We recommend to remove the pressure load from the users body and legs, before angling the back and leg support. Put a gentle back pressure on the back and leg support to remove the pressure load.

! Secure the chair when any adjustments have been made. Then place the user into the Manatee.

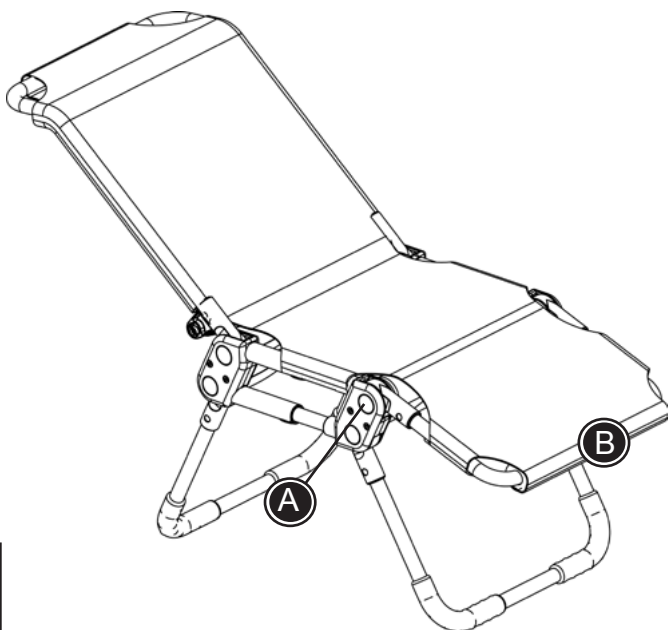

GB LEG SUPPORT ANGLING

The leg support on the Manatee angles individually. Please follow the description below when angling the back:

- 1) Press the release buttons (A) on both sides.
- 2) Angle the leg support (B) into the required position.
- 3) Please check that both release buttons (A) mesh into place after adjustment.

Further, the leg support also angles by pulling the strap underneath the chair.

! We recommend to remove the pressure load from the users body and legs, before angling the back and leg support. Put a gentle back pressure on the back and leg support to remove the pressure load.

! Secure the chair when any adjustments have been made. Then place the user into the Manatee.

GB SEAT DEPTH

The seat depth on Manatee (size 0) can be adjusted in two positions:

- 1) Dismount the screws (A) in both sides with a 4 mm Allen key.
- 2) Replace the short tubes with the long enclosed ones. Fasten the screws (A) securely.

Please follow the below to adjust the seat depth of the Manatee (size 1+2):

- 1) Loosen the screws (A) in both sides with a 4 mm Allen key.
- 2) Adjust the depth into the required position by pulling out the frame.
- 3) Fasten the screws (A) again.

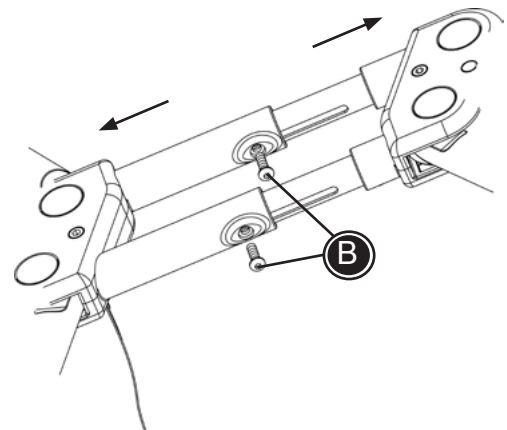
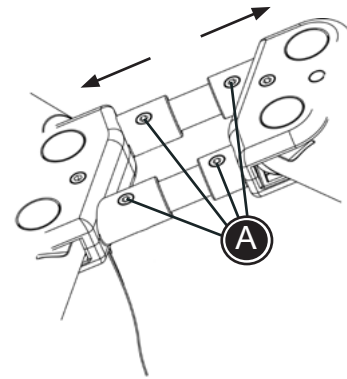

! Please check, on a regular basis, that the screws are fastened safely. Make sure that the screws mesh into the nuts.

! The user must be removed from the product before adjustment.

! Secure the chair when any adjustments have been made. Then place the user into the Manatee.

GB SEAT HEIGHT

The seat height of the Manatee can be adjusted by changing the position of the legs.

- 1) Press the release buttons (A) in both sides.
- 2) Angle the legs (B) into the wanted position.
- 3) Please check that all release buttons (A) mesh into place after adjustment

The legs also adjust when pulling out the strap underneath the seat.

! The user must be removed from the product, before angling the chair legs.

! Secure the chair when any adjustments have been made. Then place the user into the Manatee.

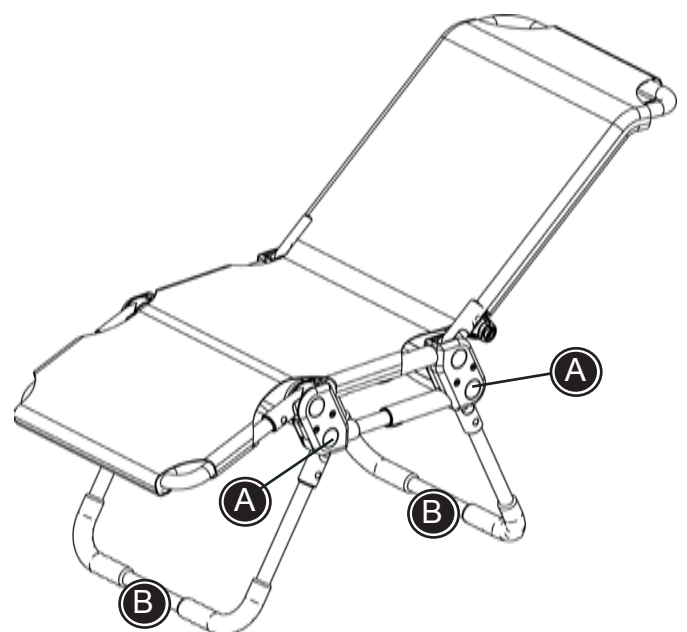

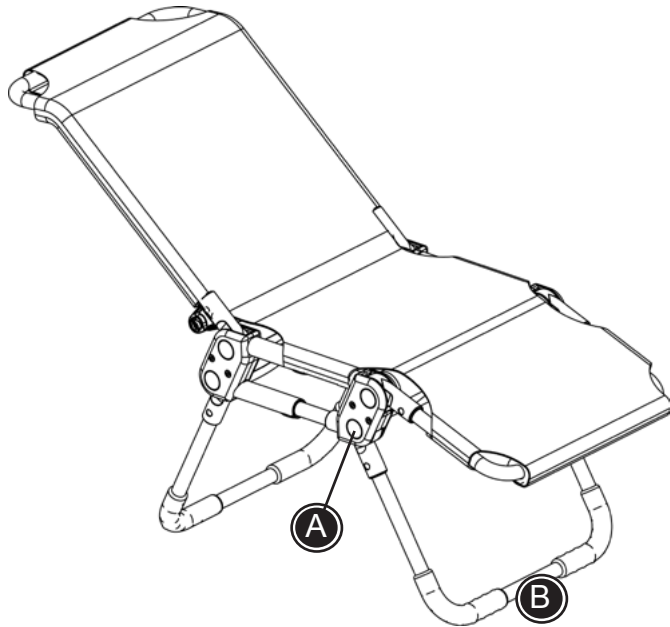

GB SEAT ANGLING

Please follow the instructions below to adjust the seat angle on the Manatee:

- 1) Press the release buttons (A) on both sides.
- 2) Angle the front leg (B) into the required position.
- 3) Please check that both release buttons (A) mesh into place after adjustment

The front leg also adjust when pulling out the strap underneath the seat.

! The user must be removed from the product, before angling the chair legs.

! Secure the chair when any adjustments have been made. Then place the user into the Manatee.

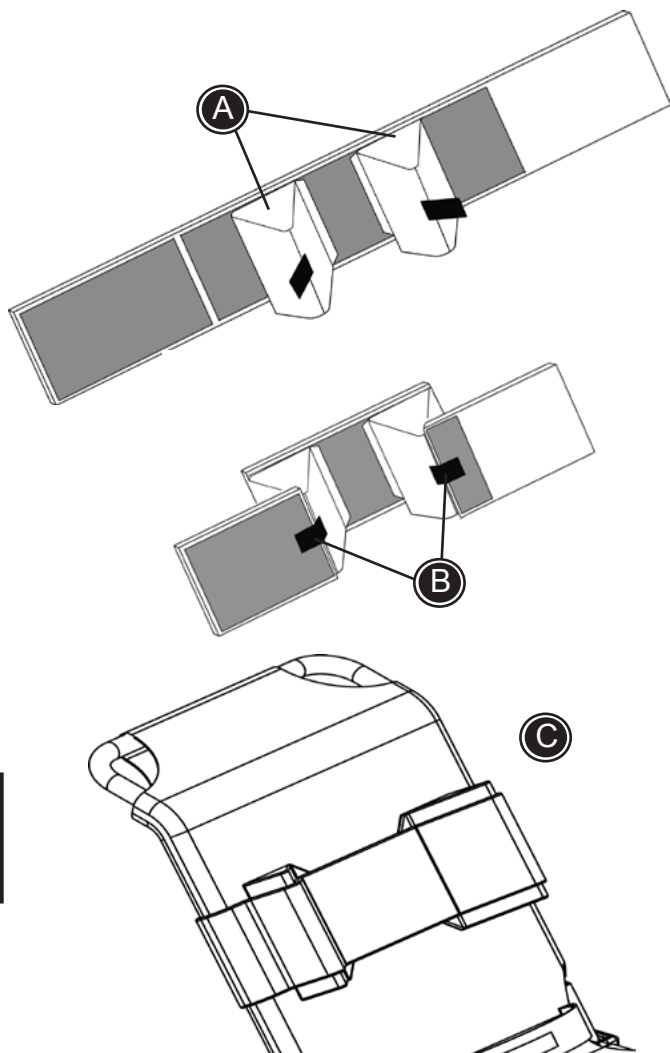

GB HEAD / SIDESUPPORT

As standard the Manatee is delivered with a head / sidesupport. The support can be used either as a head or as a sidesupport. Follow the description below to mount the support in the correct way:

- 1) Spread out the strap with the reverse up. Place the wedges on the strap in the required position (A).
- 2) Fold up the ends of the strap and fasten it to the wedges (B) with the velcro.
- 3) Turn the strap around and it is ready to be mounted on the chair (C).

! Make sure that the wedges are well fastened to the velcro on the strap.

! The head / sidesupport may not be used as a long-term support. This support is only designed to make it easier to place the user in the chair.

! Secure the chair when any adjustments have been made. Then place the user.

GB HIP SUPPORT

As standard the Manatee is delivered with a hip support. Follow the description below to mount the support the correct way:

- 1) Fasten the strap in the fittings (A) on both sides of the chair.
- 2) The hip belt is tightened with velcro and a buckle (B).

 The hip support may not be used as a long-term support. This support is only designed to make it easier to place the user in the chair.

 Secure the chair when any adjustments have been made. Then place the user into the Manatee.

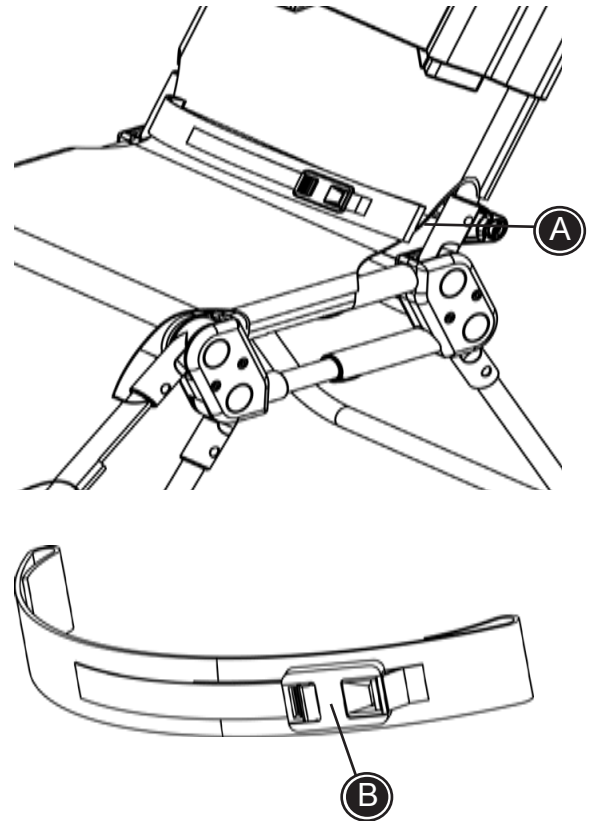

GB BODY SUPPORT

Please follow the description below to mount the body support the correct way:

- 1) Fasten the strap with velcro around the back (A).
- 2) Place the user in the chair. Mount the strap (B) around the body.
- 3) Tighten the body support with velcro and the buckle (C).

 The body support may not be used as a long-term support. This support is only designed to make it easier to place the user in the chair.

 Secure the chair when any adjustments have been made. Then place the user into the Manatee.

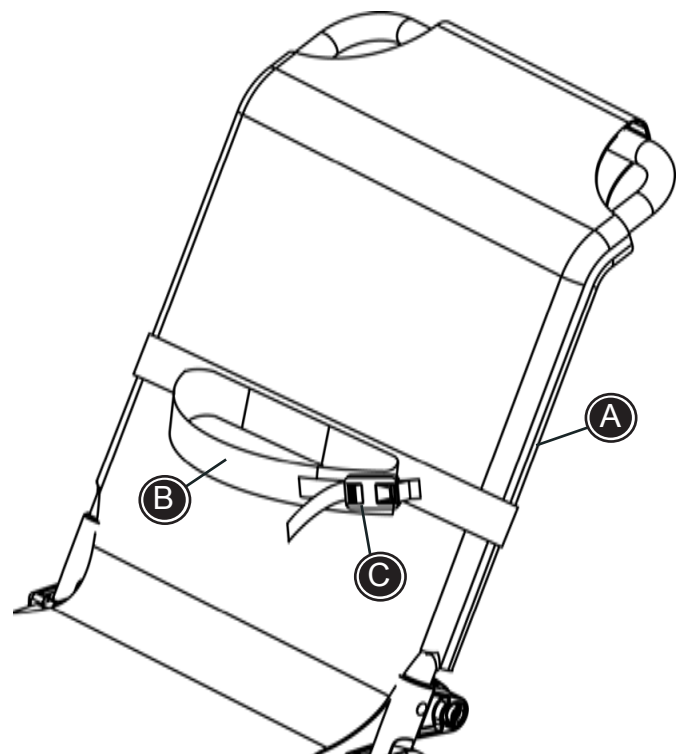

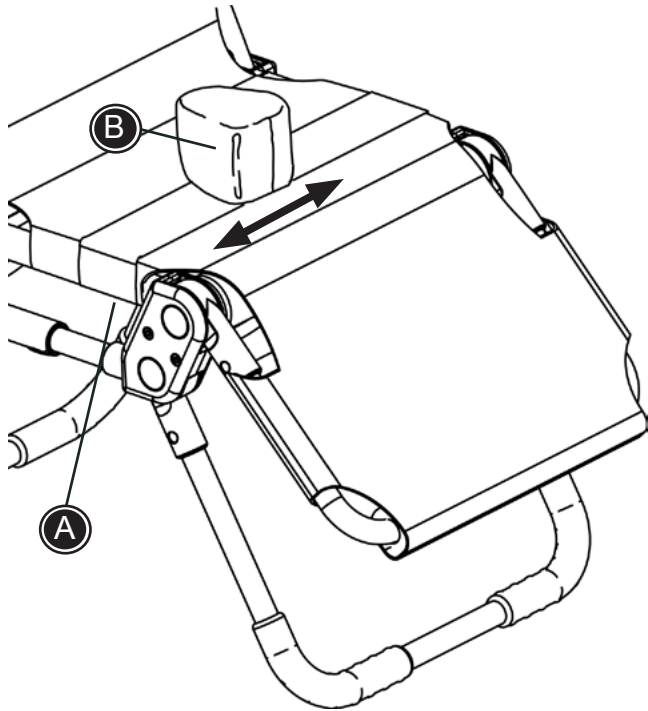

GB POMMEL WITH STRAP

Please follow the instructions below to mount the pommel and the strap the correct way:

- 1) Fasten the strap with velcro underneath the seat (A).
- 2) Adjust the pommel (B) sideways to gain the optimal position.

! The pommel with strap may not be used as a long-term support. This support is only designed to make it easier to place the user in the chair.

! Secure the chair when any adjustments have been made. Then place the user into the Manatee.

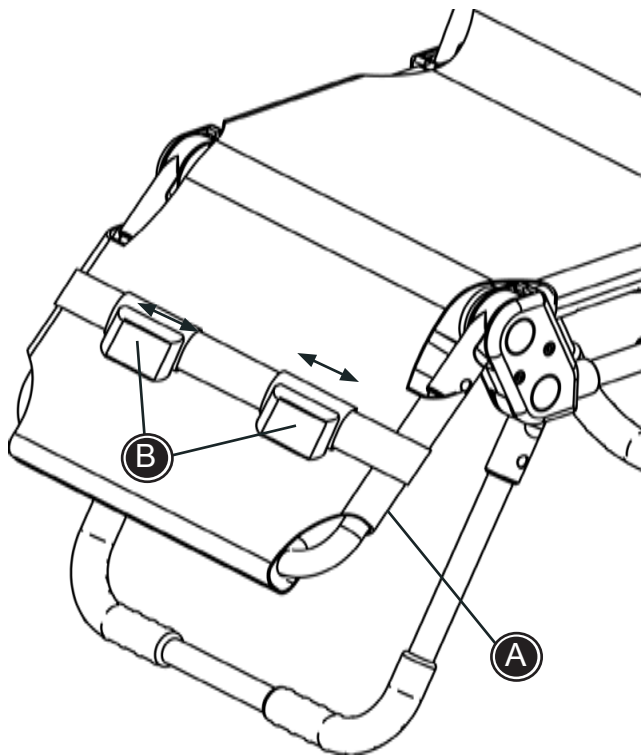

GB STRAPS FOR LEG CONTROL

Please follow the description below to mount the straps the correct way:

- 1) Fasten the strap with velcro underneath the leg support (A).
- 2) Adjust the straps (B) sideways to gain the optimal position. Fasten with velcro.

! The straps may not be used as a long-term support. This support is only designed to make it easier to place the user in the chair.

! Secure the chair when any adjustments have been made. Then place the user into the Manatee.

GB DISMOUNTING AND MOUNTING THE COVER

Follow the description below when the cover needs to be dismantled and washed:

- 1) Unzip the cover on the back (A) and underneath the seat (B).
- 2) Open the velcro underneath the chair (C) and the cover can be pulled up (D) and off the chair.

 Please look in the back of this manual regarding maintenance of the cover.

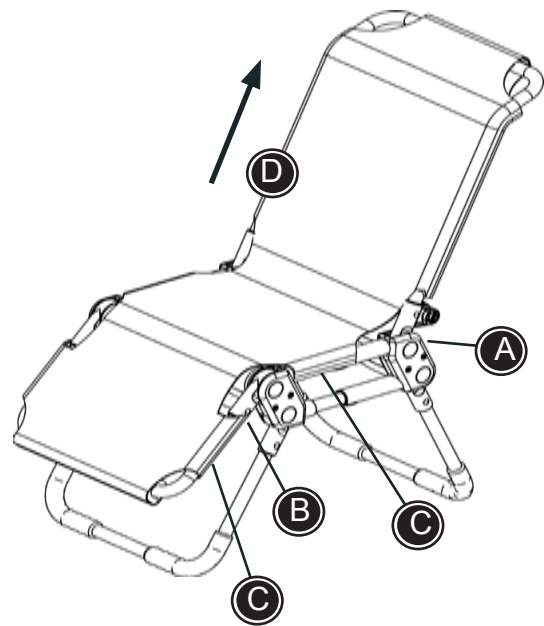

Follow the description below to remount the cover on the chair:

- 1) Put the cover over the back and pull down (D). Make sure that the foam cushions in the cover are placed around the frame.
- 2) Zip the cover on the back of the chair (A).
- 3) Mount the small cover piece with the zipper underneath the chair (B). Make sure that the velcro is pointing downwards.
- 4) Tip up the leg support (E) and the velcro underneath the seat (C) and underneath the leg support (C) can be closed. Make sure that the foam cushions in the cover are placed around the frame.
- 5) Tip down the leg support (E) and make sure the velcro is fastened correctly.

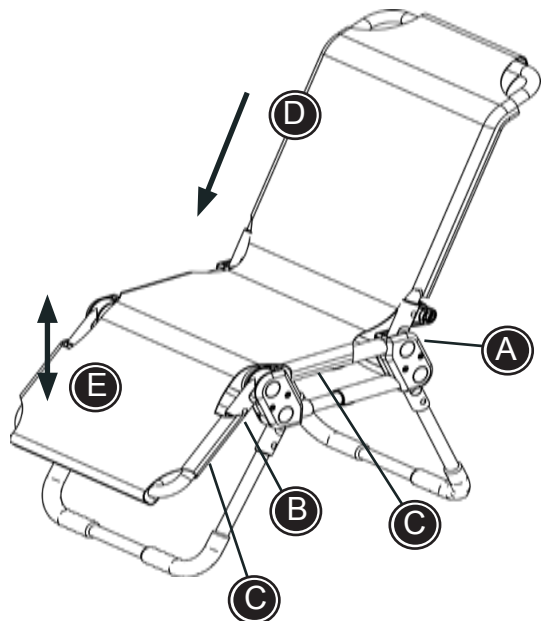

 Please check on a regular basis that the zippers (A) + (B) are safely closed.

 Please check on a regular basis that the velcro fastens safely together.

GB FOLDING THE CHAIR

The Manatee can easily be folded and stored without taking up much space.

Follow the description below to fold the Manatee correctly:

- 1) Press the release buttons (A) on both sides and move the leg support up into the horizontal position.
- 2) Press the release buttons (B) and move down the back into the horizontal position.
- 3) Press the release buttons (C) and tip up both the front and rear legs into horizontal.

The Manatee is now folded.

 The user must be removed from the product, before angling the chair legs. We recommend to remove the pressure load from the users body and legs, before angling the back and leg support. Put a gentle back pressure on the back and leg support to remove the pressure load.

 Please check that all release buttons mesh into place after adjustment.

 Please take care not to get your fingers caught between the rotary joint and the back (D). If desired, it is possible to pull out the release strap with one hand and angle the back with the other hand (E).

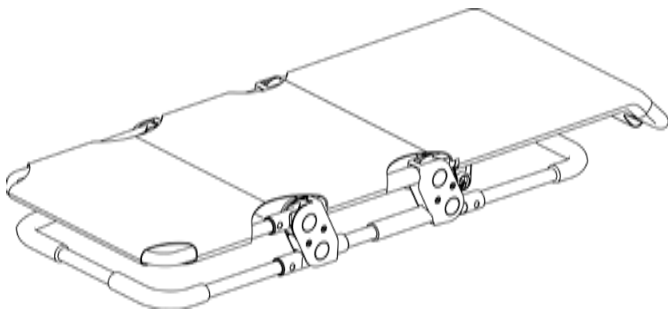
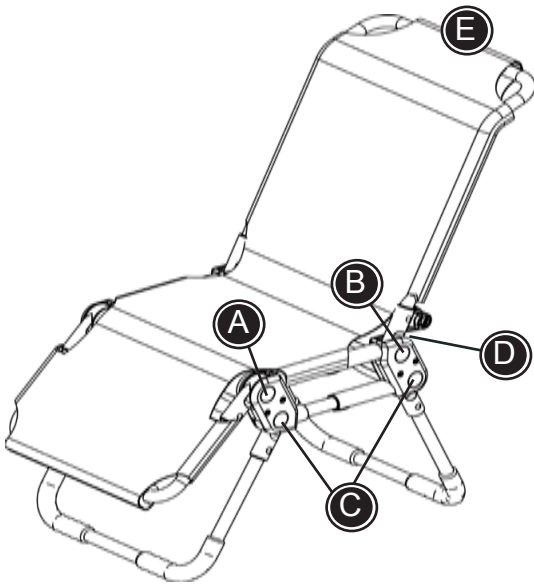

GB FRAME

Mounting the wheels:

- * Fit the 4 wheels using a spanner and tighten to ensure safe fitting.

Adjusting the frame:

- * Loosen the fingerscrews (A).
- * Unfold the frame and rise to the desired height.
- * Make sure to tighten the fingerscrews (A) properly in the wished height.

Placing the chair on the frame:

- * Lock the wheels into position using the foot operated locks.
- * Place the rear (B) of the chair in the holder on the frame (E).
- You may need to use the adjusters (G) to achieve the desired position.
- * Place the front (D) of the chair in the other holder on the frame (C).

 Pay attention that you do not get your fingers trapped when folding/unfolding the frame.

 The chair must be placed in the centre of the frame. Between the 2 rubber supports (F). Make sure that (G) is clicked into place. test the chair to make sure it is properly fitted onto the frame.

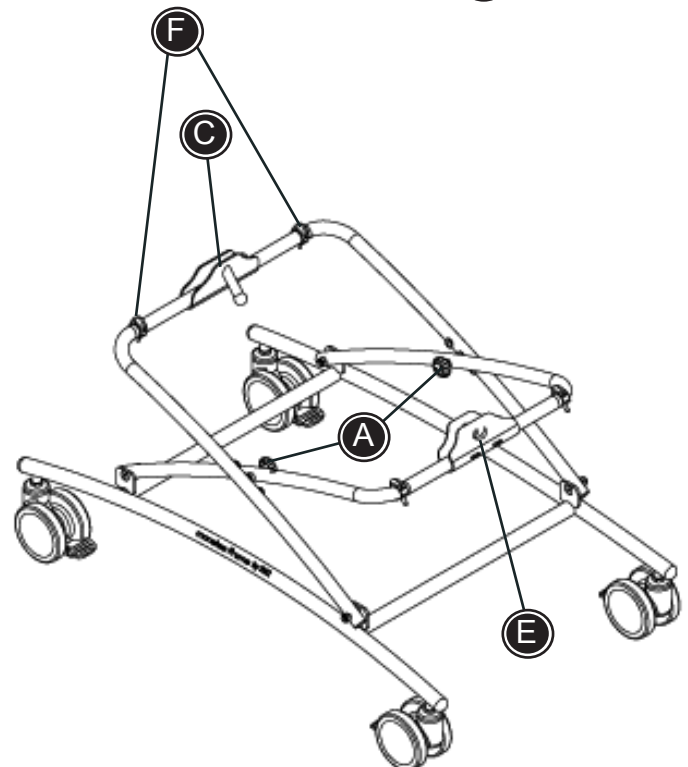
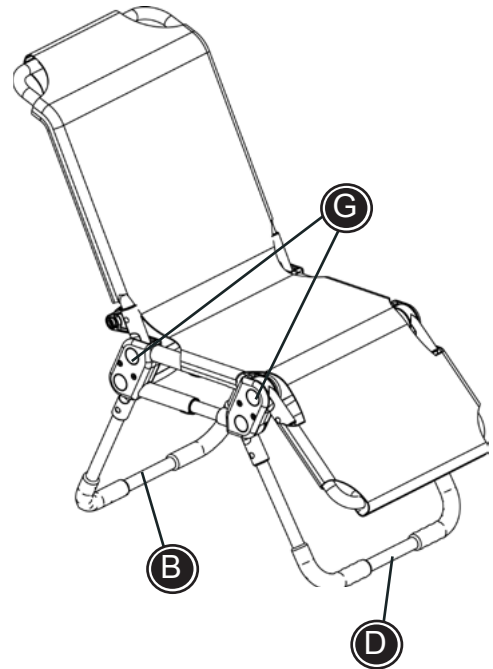

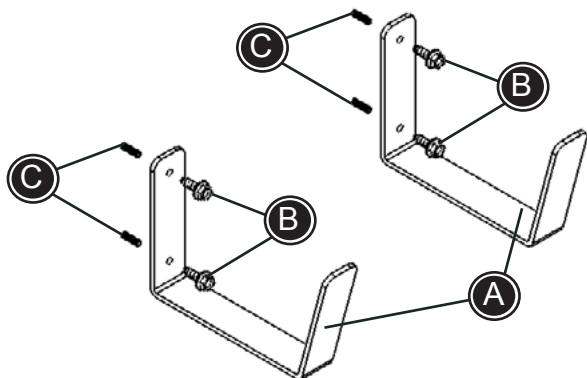

GB WALL FITTINGS FOR FRAME

- * Drill 8 mm. holes for the screws (B). Place rawlplugs (C) in the holes.
- * Screw the 2 wall fittings (A) into the wall with the screws (B).
- * Hang the folded Manatee frame on the wall fittings.

 The wall fittings are only for the Manatee frame.

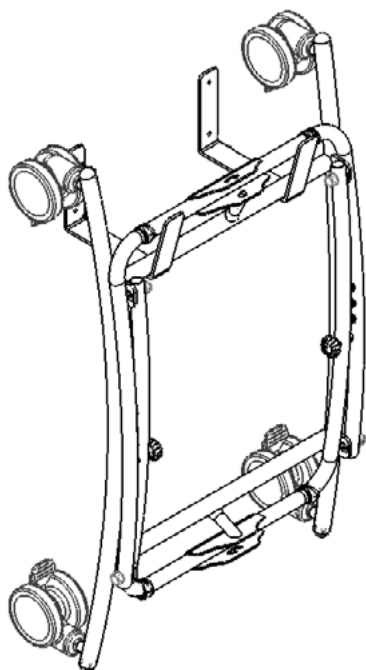

GB PRODUCT IDENTIFICATION

Size 0

A) Serial number

The label is placed on the right side of the cross bar on the back.

B) Manufacturer

The label is placed on the right side of the cross bar on the back.

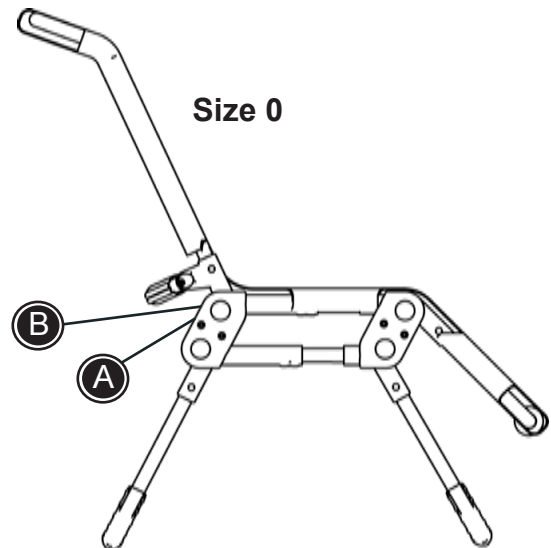

Size 1+2

A) Serial number

The label is placed on the inside of the frame at the right side of the chair.

B) Manufacturer

The label is placed on the inside of the frame at the left side of the chair.

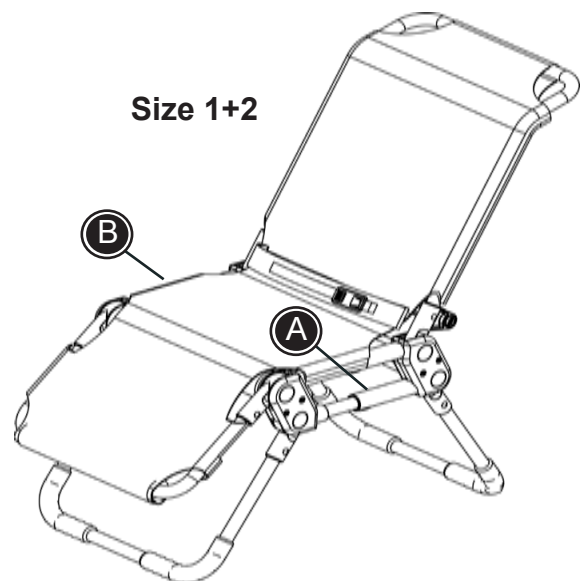

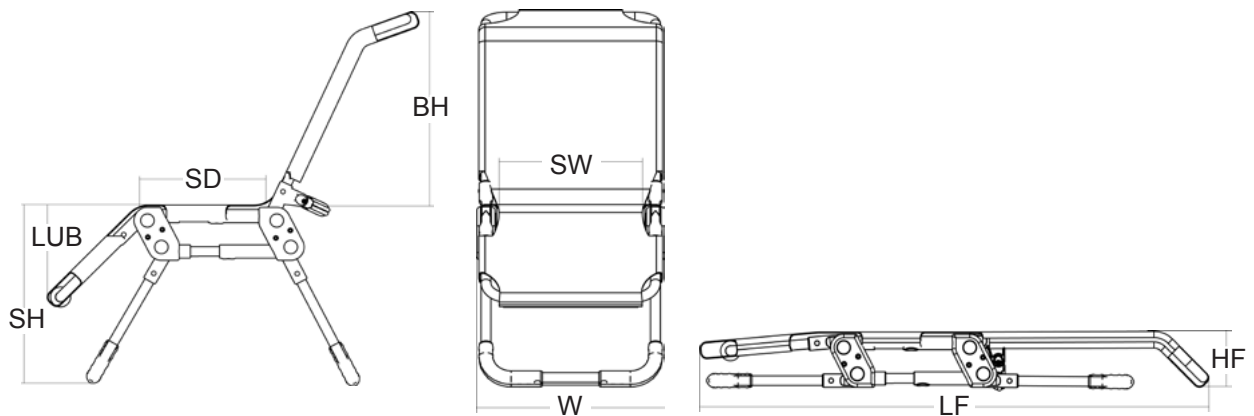

GB MEASUREMENTS

	Size 0 cm (inch)	Size 1 cm (inch)	Size 2 cm (inch)
Seat width (SW)	33 (12 ³ / ₄ "	33 (12 ³ / ₄ "	33 (12 ³ / ₄ "
Seat depth (SD)	21 & 25 (8-9 ³ / ₄ "	25-32 (9 ³ / ₄ -12 ¹ / ₂ "	33-40 (12 ³ / ₄ -15 ¹ / ₂ "
Seat height (SH)	13-43 (5-16 ³ / ₄ "	13-43 (5-16 ³ / ₄ "	13-43 (5-16 ³ / ₄ "
Back height (BH)	43 (16 ³ / ₄ "	43 (16 ³ / ₄ "	58 (22 ¹ / ₂ "
Lower leg length (LUB)	28 (11")	28 (11")	37 (14 ¹ / ₂ "
Total width (W)	42 (16 ¹ / ₂ "	42 (16 ¹ / ₂ "	42 (16 ¹ / ₂ "
Length, folded (LF)	110-117 (43-45 ³ / ₄ "	110-117 (43-45 ³ / ₄ "	135-142 (52 ³ / ₄ -55 ³ / ₄ "
Height, folded (HF)	13 (5")	13 (5")	13 (5")
Weight	4 ¹ / ₄ kg (9 ¹ / ₂ lb)	4 ¹ / ₂ kg (10 lb)	4 ³ / ₄ kg (10 ¹ / ₂ lb)
Max load/weight	50 kg (110 lb)	50 kg (110 lb)	75 kg (165 lb)

Frame

Total width	59 (23")
Total length	98 (38 ¹ / ₄ "
Height, minimum	38 (13 ³ / ₄ "
Height, middle	44 (17")
Height, maximum	48 (18 ³ / ₄ "
Seat height min., Manatee on frame	76 (29 ³ / ₄ "
Seat height middle, Manatee on frame	84 (32 ³ / ₄ "
Seat height max., Manatee on frame	90 (35")

One size

Height, folded	21 (8 ¹ / ₄ "
Weight	7,8 kg (17 lb)
Max. load / userweight	75 kg (165 lb)

GB TECHNICAL DATA

Frame: Powder lacquered Aluminium tubes

ABS parts: Glass fibre strengthened Nylon

Cover: Fire-resistant, 100% polyester

GB PRODUCER

R82 A/S
Parallelvej 3
8751 Gedved
Denmark

GB DISTRIBUTOR



Please find your distributor on www.r82.com

GB CARE AND MAINTENANCE

COVER

The cover is made of fire resistant fabric. The cover can easily be removed and can be machine washed at 50°.

FRAME

Make sure that all screws underneath the chair (A) are safely fastened, especially when the chair has been adjusted from one depth to another. The screws (B) at the rotary joints have to be inspected on a regular basis.

It is important to keep the chair clean both considering your own well-being and the validity of the warranty. When the chair has been used in water containing chlorine it has to be washed out with clean water and dried with a cloth. Make sure that all water is out of the frame. Do not use any cleaning materials containing chlorine or methylated spirit.

INSPECTION

It is important to be aware of any indications of beginning faults on the frame, PVC parts and the like.

REPAIR

If there is a fault on your bathing chair you should contact your dealer at once. Defective chairs should not be used. If your chair needs reconditioning or repair, only original R82 parts must be used. Accessories or available spare parts which are broken can be forwarded to R82 for repair. If fault occurs in the fundamental parts, the whole chair needs to be returned to R82 for repair. R82 will not be held responsible for damage or injury caused by use of non-original parts or repairs made by a non-authorized R82 person.

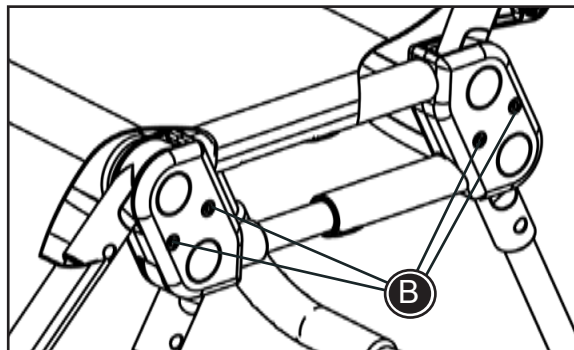
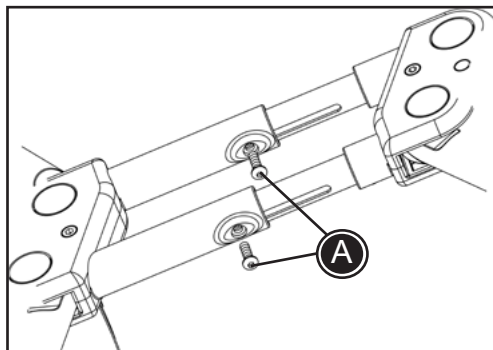

GB TROUBLESHOOTING

Problem*

Solution

The screws do not mesh into the nuts after adjusting the depth.

Slide the frame out to its longest length. Turn the seat over and slide the nut along to the hole in the frame and the screw can then be fastened securely.

The release buttons do not mesh into place.

Move the frame backwards and forwards slightly until the buttons mesh into place.

The cover has become loose.

Tighten the cover with the velcro underneath the seat and leg support.

The chair slips on the bath bottom.

The rubber cover may be damaged. Please contact R82 and replace the cover.

The velcro does not fasten together

Remove any dirt from the velcro. If this do not work the cover or accessory has to be replaced. Please contact R82.

* The user/helper may experience several of these problems in a bathing chair that is incorrectly adjusted or is being incorrectly used.



